

20 Gallon Smart Foam Unit

Service Manual

FI-20N-SM

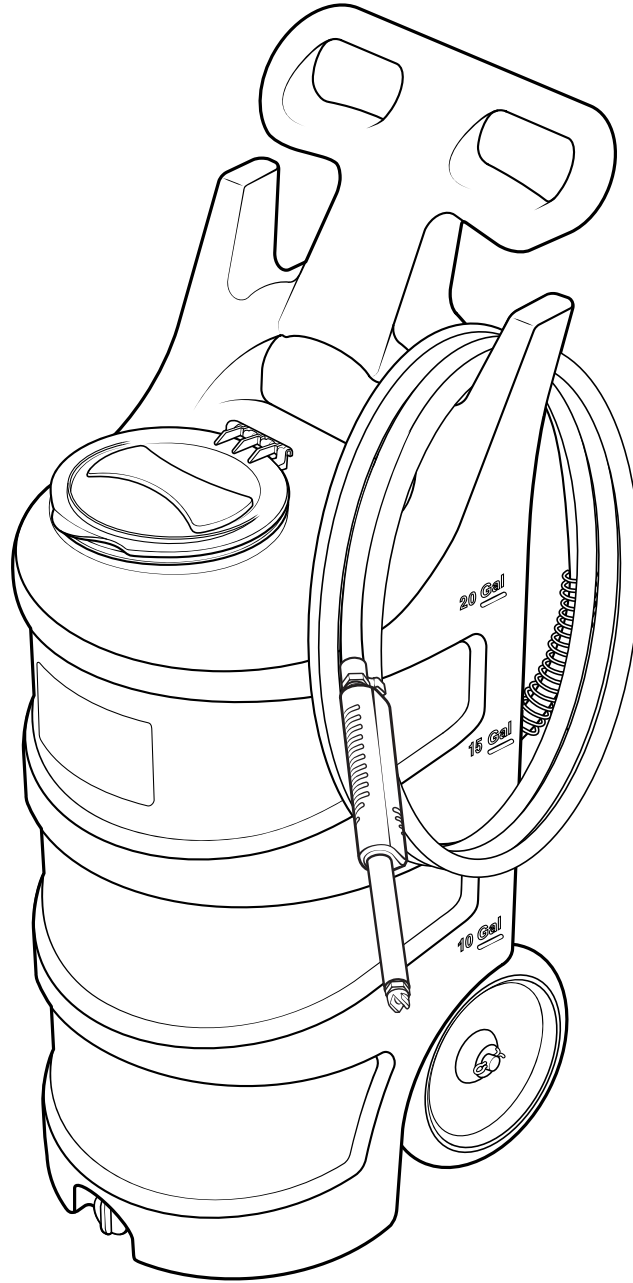

READ ALL INSTRUCTIONS BEFORE USING OR
SERVICING THIS UNIT. KEEP THIS MANUAL IN A
LOCATION THAT IS READILY AVAILABLE TO USERS
AND SERVICE TECHNICIANS.

English (Original Instructions)



Scan this code for
service manual

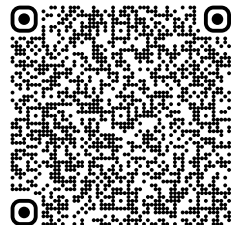

Safety

WARNING

PEOPLE OR OBJECTS CAN BE HURT OR DAMAGED IF THIS UNIT IS NOT USED CORRECTLY!



Failure to read all the instructions before operating the unit may result in personal injury or death from the improper use or the chemical solution. Anyone handling, operating or using the unit must read and understand the instructions in the manual. The buyer assumes all responsibility for safety and proper use in accordance with the instructions.



Using or servicing the unit without appropriate personal protective equipment (PPE) may result in serious injury such as burns, rashes, eye, throat or lung damage and death. Always wear PPE as indicated in the Safety Data Sheet (SDS) when using or servicing the unit. Protect eyes, skin, and lungs against drifting spray.



Chemical solutions may pose a health risk and death if they contact the skin or eyes, are inhaled or swallowed. Always read and follow all chemical safety precautions and handling instructions provided by the chemical manufacturer and the SDS associated with the chemical solution before using the unit.



Pressure within the equipment may cause an unexpected release of the chemical solution and cause serious injury such as burns, rashes, eye damage, throat or lung damage and death. Always depressurize and clean the unit after each use.

Always keep the air trigger port clean and free of blockages or debris. If the port becomes dirty or blocked, disconnect the compressed air source from the unit immediately and clean out the port before proceeding.

Using the unit with fluid temperatures above 100°F (37.8°C) may result in scalding, burns, serious injury or death. DO NOT use a solution with a temperature above 100°F (37.8°C).

Operating the unit when damaged or leaking may result in exposure to chemical solutions, serious injury or death. Never use the unit if it is damaged or leaking.

Never point the discharge wand at yourself, another person, or any object you do not want covered in chemical.



Using incoming air pressure exceeding 100 psi (6.9 bar) may result in pressure buildup, explosion, serious injury or death. DO NOT exceed 100 psi (6.9 bar) incoming air pressure when operating the unit.

Use of hydrocarbons and flammable products may result in explosions, fire and serious injury or death. Never use hydrocarbons or flammable products with the unit.



Mixing an alkaline with an acid may result in a chemical reaction. Overheating of the mixture may cause it to splatter caustic compounds or release hazardous fumes, gas and vapors. Always flush the unit with fresh water thoroughly when switching from an alkaline to an acid or an acid to an alkaline.

NOTICE

Servicing or modifying this unit with parts not listed in this manual may cause the unit to operate improperly. Do not use unauthorized parts when servicing the unit.

Use of an air lubricator before the unit may result in diminished performance and damage to the unit. Do not use an air lubricator before the unit.

Moisture in the air lines will damage the pump and diminish the pump life. The air must be filtered, clean, dry and free of moisture. If needed, install an air dryer before the unit.

PROTECT THE ENVIRONMENT



Please dispose of packaging materials, old machine components, and hazardous fluids in an environmentally safe way according to local waste disposal regulations.

Service Guide

⚠ WARNING

Performing any maintenance with the unit pressurized and connected to the air supply may result in serious injury or death. Always ensure that the unit has been depressurized and disconnected from the air supply before conducting any maintenance. Servicing or modifying this unit with parts not listed in this manual may cause the unit to operate improperly. Do not use unauthorized parts when servicing the unit.

Maintaining Your Unit

To keep your unit operating properly, periodically perform the following maintenance procedures:

- Inspect the pump for wear and leaks.
 - Inspect all hoses for leaks or excessive wear. Ensure hose clamps are in good condition and properly secured.
 - Check the air trigger port on the handle for debris and clean as needed. When cleaning, be careful not to push debris into the port, as it may become lodged inside and create a blockage.
 - Check suction line and strainer for debris. Clean as needed.
 - Replace the filter located within the air regulator as needed. Clean by unthreading the air regulator bowl from the air regulator.
 - Drain your air compressor tank on a regular basis to help extend pump life. An air source with a high moisture content will accelerate pump wear.
- Note:** If your air source has a high moisture content, install a water separator to the air fitting on backplate. See Page 8 for more details. (Back plate assembly)

Servicing Your Unit

Most repairs on the unit can be performed with the following tools:

- Crescent wrench (2x)
- 7/16 in. (11 mm) open-ended wrench
- Flat head screwdriver
- Thread seal tape
- #2 Phillips head screwdriver
- #3 Phillips head screwdriver
- Hose cutters
- Knife

Troubleshooting Your Unit

If your unit is not operating properly, try using these troubleshooting tips:

Issue	Solution
Air regulator bowl or air filter has debris such as water, oil, or rust particles	<ul style="list-style-type: none"> Clean by unthreading the air regulator bowl from the air regulator.
Pump is cycling improperly	<ul style="list-style-type: none"> The needle valve is open too far. Close and readjust the needle valve as described in the operation section. Ensure proper foaming chemical and concentration are being used.
Air passes through pump without cycling	<ul style="list-style-type: none"> The pump needs to be replaced.
The solution backs up into the air regulator bowl	<ul style="list-style-type: none"> The check valve needs to be replaced.
Foam comes out wet, no matter where the needle valve is positioned	<ul style="list-style-type: none"> Check for proper air pressure on air gauge. Air regulator is factory set at 50 psi (3.4) bar. Operating range is 40 to 80 psi (2.8 to 5.5 bar) with 5 to 10 CFM (141.6 to 283.3 l/min). The check valve may need to be replaced. Verify correct chemical concentration is being used.
Unit activates when the air trigger port is not covered	<ul style="list-style-type: none"> Verify air trigger port is clean and free of blockages or debris, and discharge hose is not kinked or obstructed If the problem persists, try bypassing the air trigger. To do this, disconnect the ¼ in. hose from the wand. Point wand in a safe direction and connect an air line to the unit. Then, use your thumb or finger to seal the open port of the ¼ in. hose at the wand. <ol style="list-style-type: none"> If unit activates when you connect the air line, the valve block may need to be replaced. If unit does not activate when you connect the air line, hose or wand assembly may need to be replaced.
Unit does not activate when air trigger port is covered	<ul style="list-style-type: none"> Confirm the incoming air supply is consistently 50 psi (3.4 bar) on the air gauge. If the problem persists, the valve block may need to be replaced.
The unit operates at a reduced pressure	<ul style="list-style-type: none"> Check suction line and strainer for debris or damage. Clean or replace as needed. To prevent damage to the unit, the strainer must always be used. Check the air compressor supplying the unit. If the pressure is less than 40 psi (2.8 bar), turn off the unit until the compressor can catch up. If the air supply is 50 psi (3.4 bar) or above, check the air gauge, which should read near 50 psi (3.4 bar). If the air gauge reads more or less than 50 psi (3.4 bar), adjust pressure by turning the knob on the top of the air regulator. Check if the stainless steel mixing mesh is plugged. Remove and clean it by following the instructions below: <ol style="list-style-type: none"> Verify the unit is not plugged into an air supply and then relieve all stored pressure in the unit by turning the ball valve to the open position. Remove discharge hose from hose barb on back of the unit. Open back plate assembly and hold stainless tee with wrench to remove hose barb from tee fitting. Remove the screen and the mixing mesh from inside the tee fitting. Clean any particles from the mixing mesh and the screen. If the mixing mesh has a lot of foreign particles in it, make sure the suction strainer is still in place. Replace the mixing mesh and screen into the back of the tee. Screw the stainless hose barb back into the tee. <p>Note: It is recommended to use a pipe thread sealant when reinstalling the stainless hose barb back into the tee fitting.</p>

Tank Assembly

Front view

TNKA-20N-BK:

20 gallon natural tank assembly - black* lid - includes drain plug, wheels, suction valve, and backplate thumb nuts

LDA-7BK:

Lid assembly - includes 7 in. black* lid, lid flange, hinge pin, and mounting screws

Item number	Description	
1	LD-PIN	Hinge pin for 7 in. lid and flange
2	LD-7BK-LID	Lid - 7 in. - polypropylene - black*
3	S812-FH	Screw - #8 x 1/2 in. - stainless steel - flat head Phillips
4	LD-7BK-FLNG	Lid flange - 7 in. - polypropylene - black*

* Additional colors available, see datasheet for options.

Item number	Description	
5	TNK-20N	Tank - 20 gallon natural - portable
6	DPA	Drain plug assembly for portable units - includes gasket

LDA-7BK

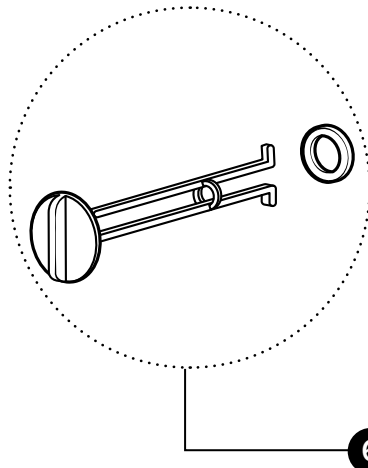
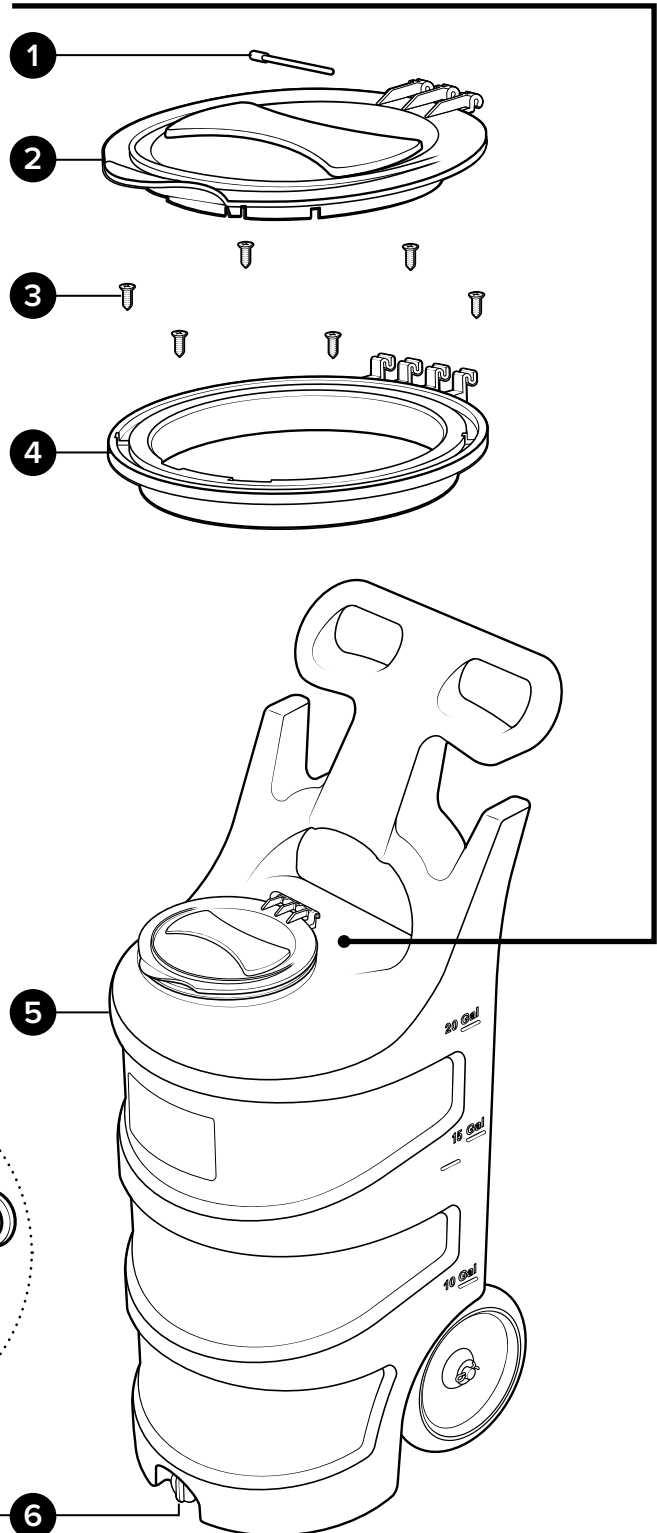

Tank Assembly

Back view

TNKA-10N-BK:

10 gallon natural tank assembly - black* lid - includes drain plug, wheels, suction valve, and backplate thumb nuts

BPTNA:

Back plate thumb nut assembly - includes bolt, thumb nut, and tether

Item number	Description
1	BST1420118-VS Bolt - set - ¼-20 x 1 ½ in. - stainless steel - Vibra-Seal
2	TN1420 Thumb nut - ¼-20 x 1 ¼ in. - PP - brass insert - assembled with tether

VLVA-BVPVC34:

Suction valve assembly - includes ¾ in. PVC valve, bushing, ¾ in. hose barb elbow, and screw band clamp

Item number	Description
3	SSC38 Screw band clamp - stainless steel - for ¾ in. hose
4	BVPVC34MF Ball valve - PVC - ¾ NPT to ¾ FNPT - Buna seal
5	HHPB3414 Hex head poly bushing ¾ MPT x ¼ FPT
6	HBSEL1438 Hose barb - stainless steel - elbow - ¼ in. MPT x ¾ in. barb

WHLA-AXL14:

10 in. wheel assembly - includes 14 in. axle, axle plate, bolts, washers, and cotter pins

Item number	Description
7	COT Cotter pin - stainless steel - ⅛ in. dia x 1 in. long
8	PLSS-AXL Axle plate - stainless steel - 2.5 in. x 1 in. - 2 holes
9	AXL14 Axle - stainless - 0.625 dia. x 14.5 in.
10	B142012-VS Bolt - ¼-20 x ½ in. - stainless steel - truss head Phillips - Vibra-Seal
11	W10 Wheel - 10 in. - non-marking
12	FW58 Flat washer for ⅝ in. od pipe or axle - stainless steel - 0.64 in. id x 1.2 in. od x 0.05 in. thk

BPTNA

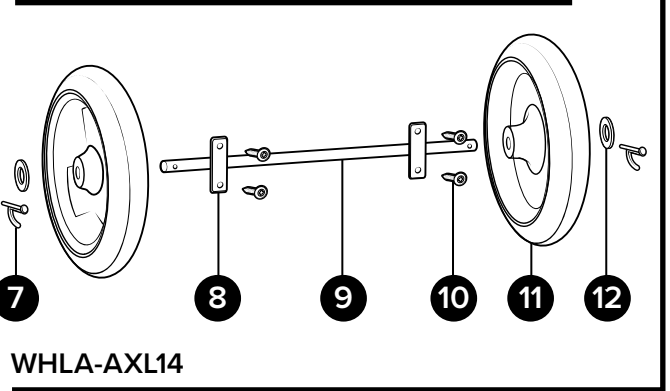
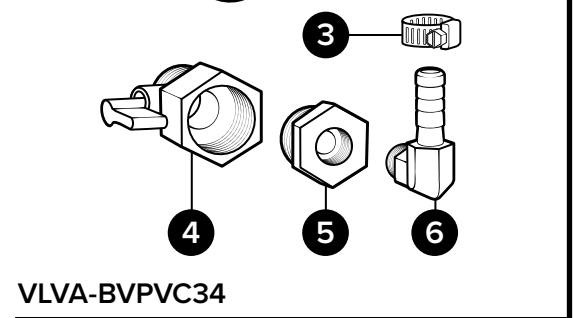
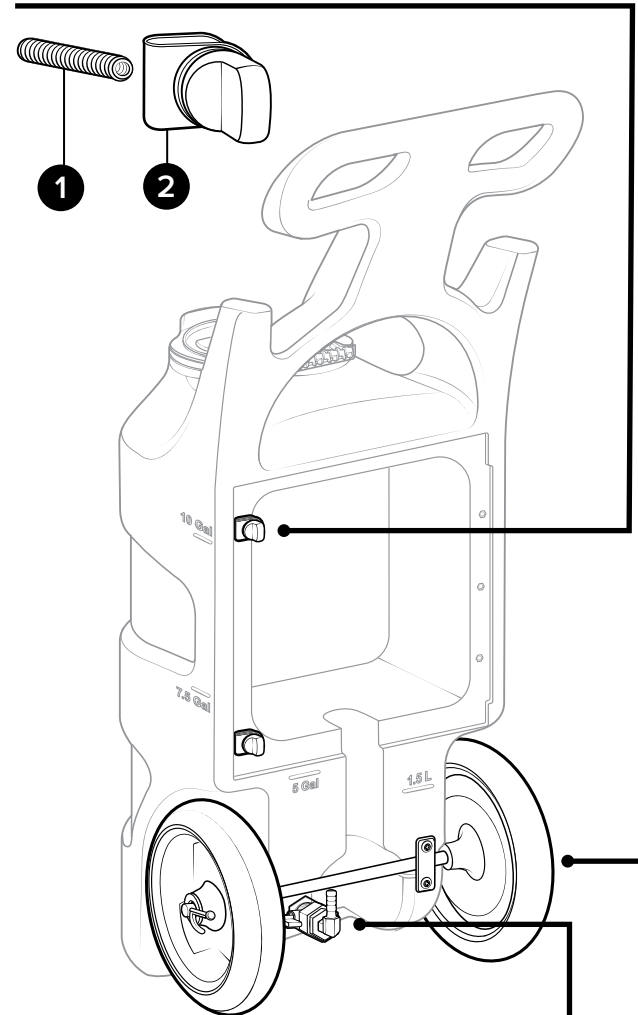

Back Plate Assembly

Inside view

PA-PF-SM:

Plate assembly for portable smart foam units with 5/8 and 1/2 in. bonded hose - Santoprene pump

Additional plate assembly pump options:

PA-PFK-SM: Kalrez pump

PA-PFV-SM: Viton pump

Item number	Description
1 A P56	Pump with Santoprene seals - includes hose barbs, air fitting, and exhaust barb
B P56K	Pump with Kalrez seals - includes hose barbs, air fitting, and exhaust barb
C P56V	Pump with Viton seals - includes hose barbs, air fitting, and exhaust barb
2 NV14	Needle valve - 1/4 in. NPT - includes black knob
3 R25	Air regulator - two 1/4 in. FPT ports - two 1/8 in. FPT ports - includes filter and bowl
4 AG100	Air gauge - 1/8 in. NPT - 100 PSI dry model
5 CV38-AP	Check valve - 3/8 in. barbs - PVC body - Hastelloy spring - Teflon ball - white
6 SM-PV	Pneumatic valve for smart units
7 FW14NPT	Flat washer for 1/4 in. NPT - stainless - 0.57 in. id x 1.28 in. od x 0.08 in. thk
8 HBFSS1438	Stainless hose barb 1/4 FPT x 3/8 barb
9 STR38-IL	In-line strainer - 3/8 barb - EPDM gasket - 20 mesh SS - black bowl
10 H14BL-F	1/4 in. id blue hose - hybrid TPE - available per ft.
11 H38BL-F	3/8 in. id blue hose - hybrid TPE - available per ft.
12 SST12HB38A-MX	Stainless tee assembly - 1/2 in. FPT x 3/8 in. SS hose barb - includes mixing media and screen

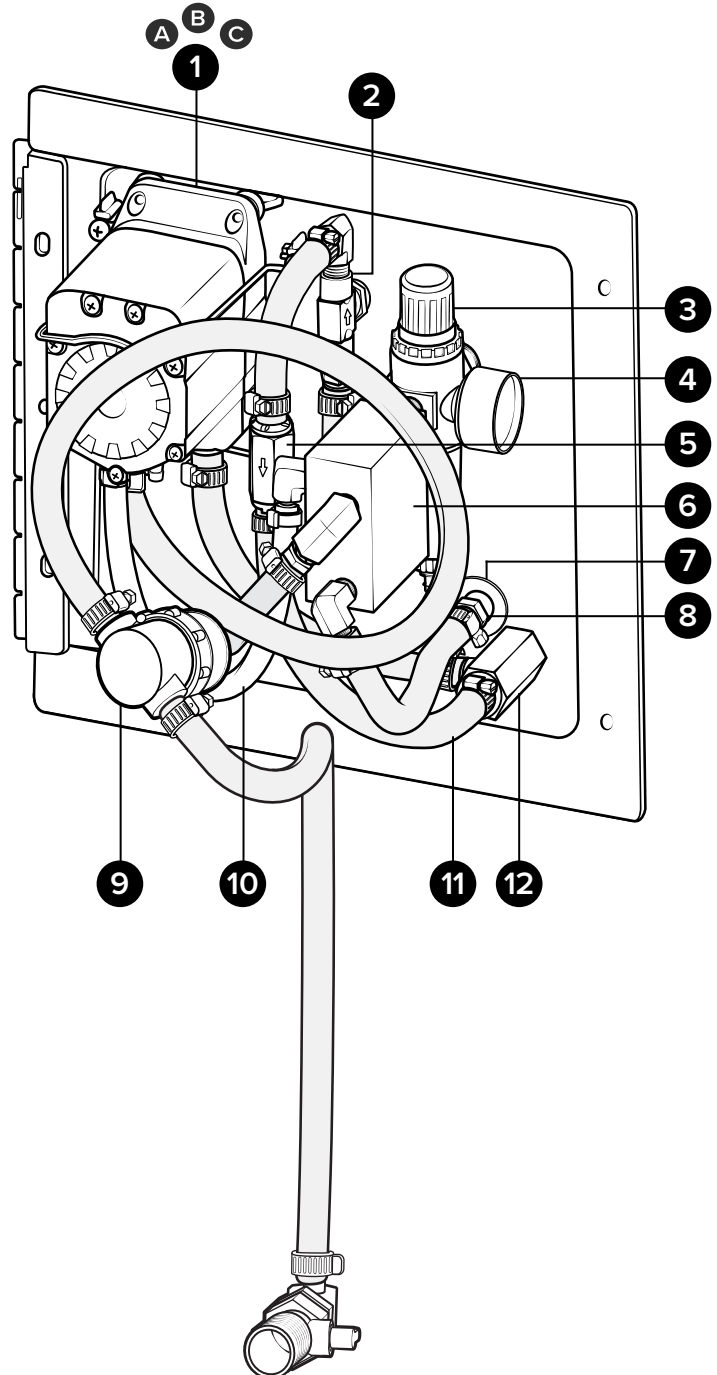

Back Plate Assembly

Back view

PA-PF-SM:

Plate assembly for portable smart foam units with 5/8 and 1/2 in. bonded hose - Santoprene pump

Additional plate assembly pump options:

PA-PFK-SM: Kalrez pump

PA-PFV-SM: Viton pump

Item number	Description
1	NV14-HNDL Black knob for needle valve
2	SSSFN12 Serrated flange nut - stainless - 1/2 in.
3	SSA14BKH Bulkhead adapter - stainless - 1/4 NPT x 1/4 NPSM
4	AP14 Air fitting 1/4 MPT x plug - nickel-plated brass
5	FW12NPT-THK Flat washer for 1/2 in. NPT - thick - stainless - 0.88 in. id x 1.5 in. od x 0.12 in. thk
6	FW12NPT Flat washer for 1/2 in. NPT - stainless - 0.88 in. id x 1.5 in. od x 0.05 in. thk
7	HBSS1258 Stainless hose barb 1/2 MPT x 5/8 barb
8	HBSS1414 Stainless hose barb 1/4 MPT x 1/4 barb

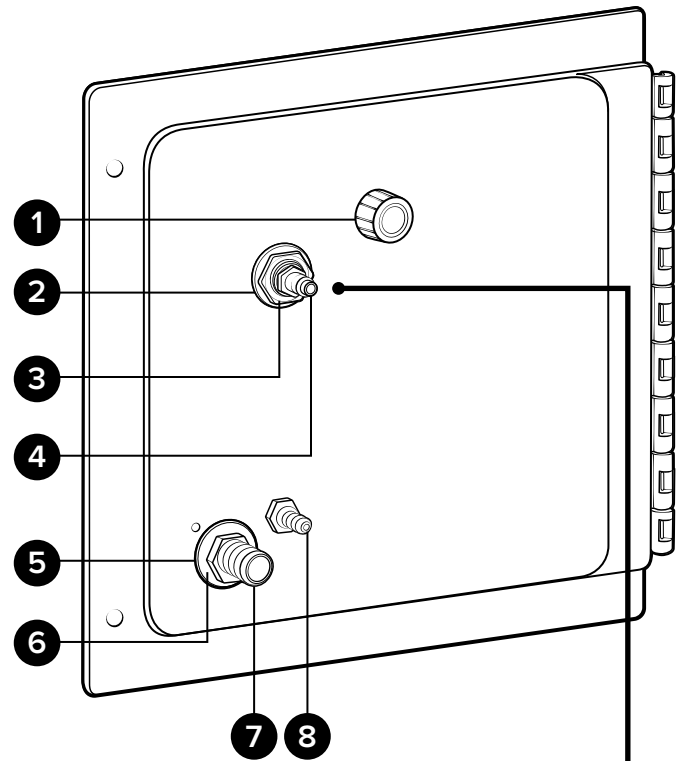

Optional Components

WSA-20CFM:

Water separator assembly - 20 CFM - 1/4 in. FPT ports - includes air plug and union fittings

Item number	Description
9	SN1414 Stainless hex nipple 1/4 MPT x 1/4 MPT
10	SSU14 Stainless steel union - 1/4 in. FPT
11	WS-20CFM Water separator - 20 CFM - 1/4 in. FPT ports
12	AP14 Air fitting 1/4 MPT x plug - nickel-plated brass

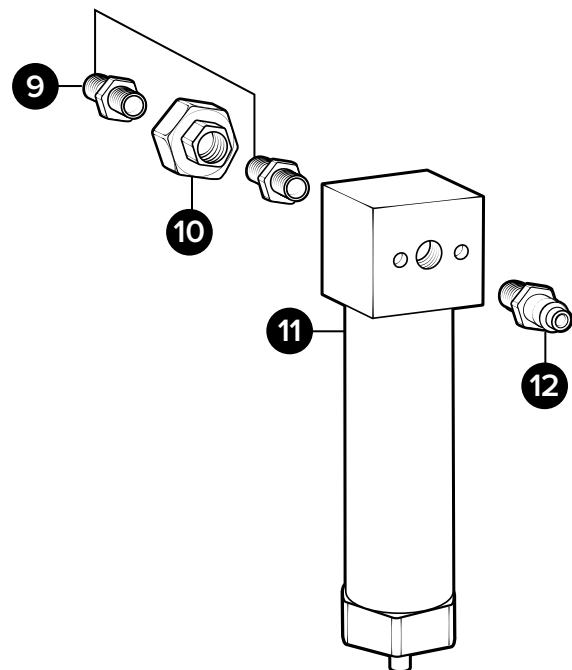

WSA-20CFM*

*Optional assembly sold separately

Back Plate Sub-assemblies

NVA-NV14-PF:

Needle valve assembly for portable foam units - includes hose barbs, and screw band clamps

Item number	Description	
1	HBSEL1438	Stainless hose barb ¼ MPT x ⅜ barb elbow
2	NV14-HNDL	Black knob for needle valve
3	NV14	Needle valve - ¼ in. NPT - includes black knob
4	HBSS1438	Stainless hose barb ¼ MPT x ⅜ barb
5	SSC38	Screw band clamp - stainless steel - for ⅜ in. hose

SST12HB38A-MX:

Stainless tee assembly - ½ in. FPT x ⅜ in. barb - includes mixing media and screen

Item number	Description	
6	SST12HB38	Stainless tee ½ FPT ⅜ barb - no mixing media
7	MXA- PF	Mixing assembly - portable foam - includes mixing media and screen

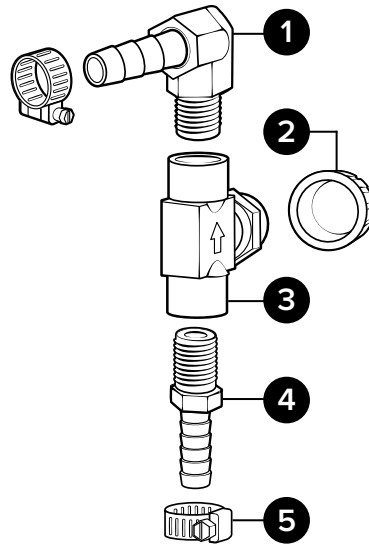
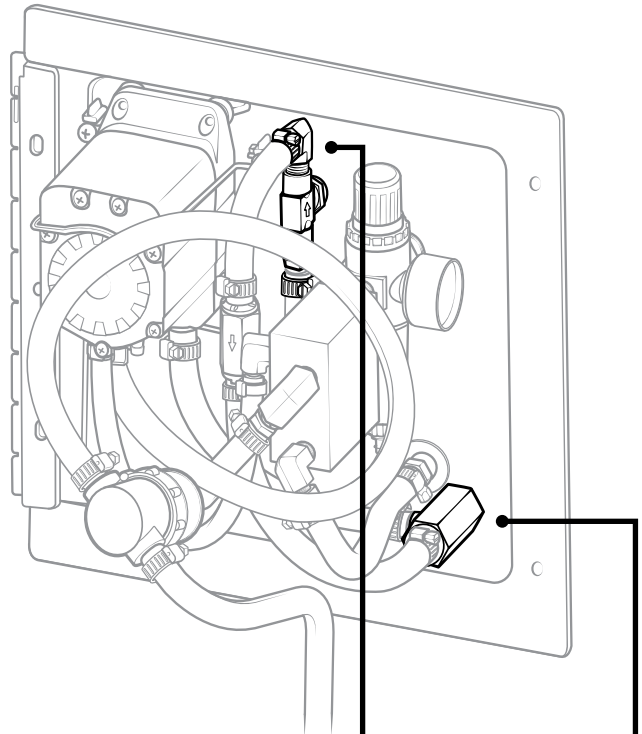

NVA-NV14-PF

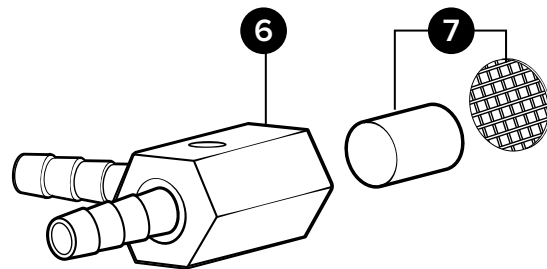

SST12HB38A-MX

Back Plate Sub-assemblies

RGA-R25-PF-SM:

Air regulator assembly for portable smart foam units - includes air gauge, valve, pump barb, hose, bulkhead fittings, and air plug

Item number	Description
1	HBB14P ¼ in. hose barb - brass - for G57/P56 air fitting with o-ring
2	EC14 Ear clamp - Oetiker - stainless steel - for ¼ in. hose
3	H14BL-F ¼ in. id blue hose - hybrid TPE - available per ft.
4	SSC38 Screw band clamp - stainless steel - for ¾ in. hose
5	H38BL-F ¾ in. blue hose - hybrid TPE - available per ft.
6	HBSEL1414 Hose barb - stainless steel - elbow - ¼ in. MPT x ¼ in. barb
7	HBSS1438 Hose barb - stainless steel - ¼ in. MPT x ¾ in. barb
8	SSE14 Stainless street elbow ¼ in.
9	HBSEL1438 Stainless hose barb ¼ MPT x ¾ barb elbow
10	SM-PV Pneumatic valve for smart units
11	SN1414 Stainless hex nipple ¼ MPT x ¼ MPT
12	R25 Air regulator - two ¼ in. FPT ports - two ⅛ in. FPT ports - includes filter and bowl
13	SSA14BKH Bulkhead adapter - stainless - ¼ NPT x ¼ NPSM
14	SSSFN12 Serrated flange nut - stainless - ½ in.
14	AP14 Air fitting ¼ MPT x plug - nickel-plated brass
16	AG100 Air gauge - ⅛ in. NPT - 100 PSI dry model

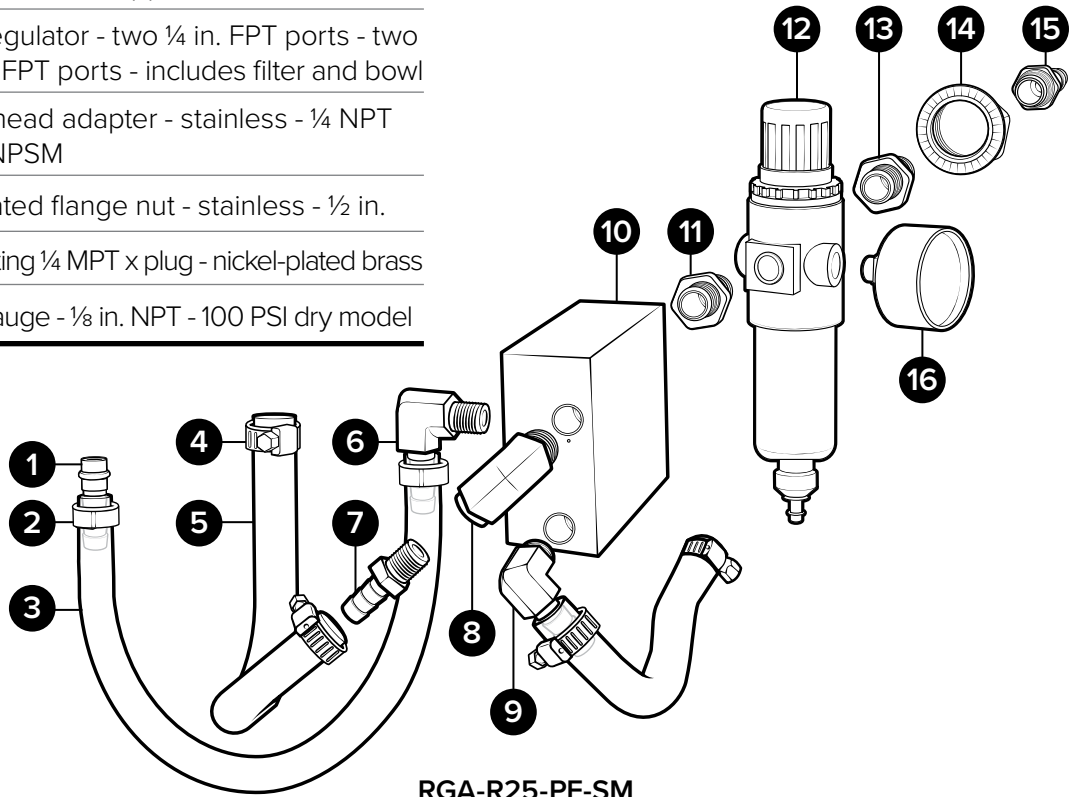
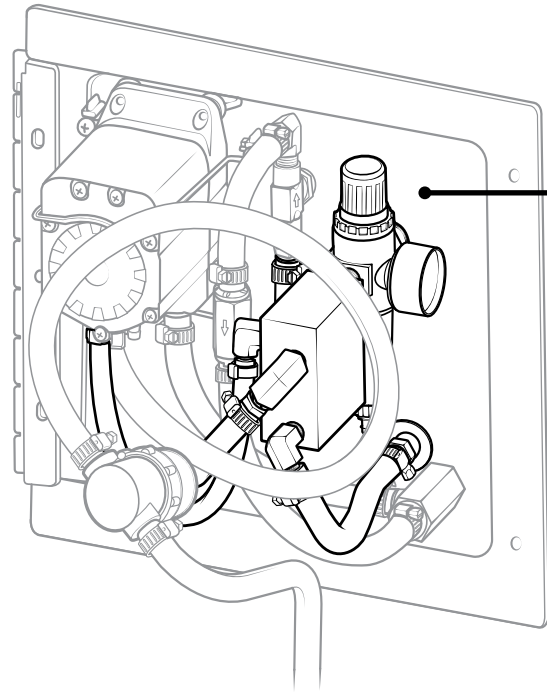

RGA-R25-PF-SM

Back Plate Sub-assemblies

SCTNA-PF:

Suction assembly for portable foam units - includes suction valve, hose, in-line strainer, and pump hose barb - for Santoprene pump

Additional suction assembly options:

SCTNA-PFK: Portables with Kalrez pump

SCTNA-PFV: Portables with Viton pump

Item number	Description
1	A HB5638 Hose barb for P56 pump - EPDM o-ring
	B HB5638K Hose barb for P56K pump - Kalrez o-ring
	C HB5638V Hose barb for P56V pump - Viton o-ring
2	STR38-IL In-line strainer - 3/8 barb - EPDM gasket - 20 mesh SS - black bowl
3	SSC38 Screw band clamp - stainless steel - for 3/8 in. hose
4	H38BL-F 3/8 in. id blue hose - hybrid TPE - available per ft.
5	HBSEL1438 Hose barb - stainless steel - elbow - 1/4 in. MPT x 3/8 in. barb
6	HHPB3414 Hex head poly bushing 3/4 MPT x 1/4 FPT
7	BVPVC34MF Ball valve - PVC - 3/4 NPT to 3/4 FNPT Buna seal

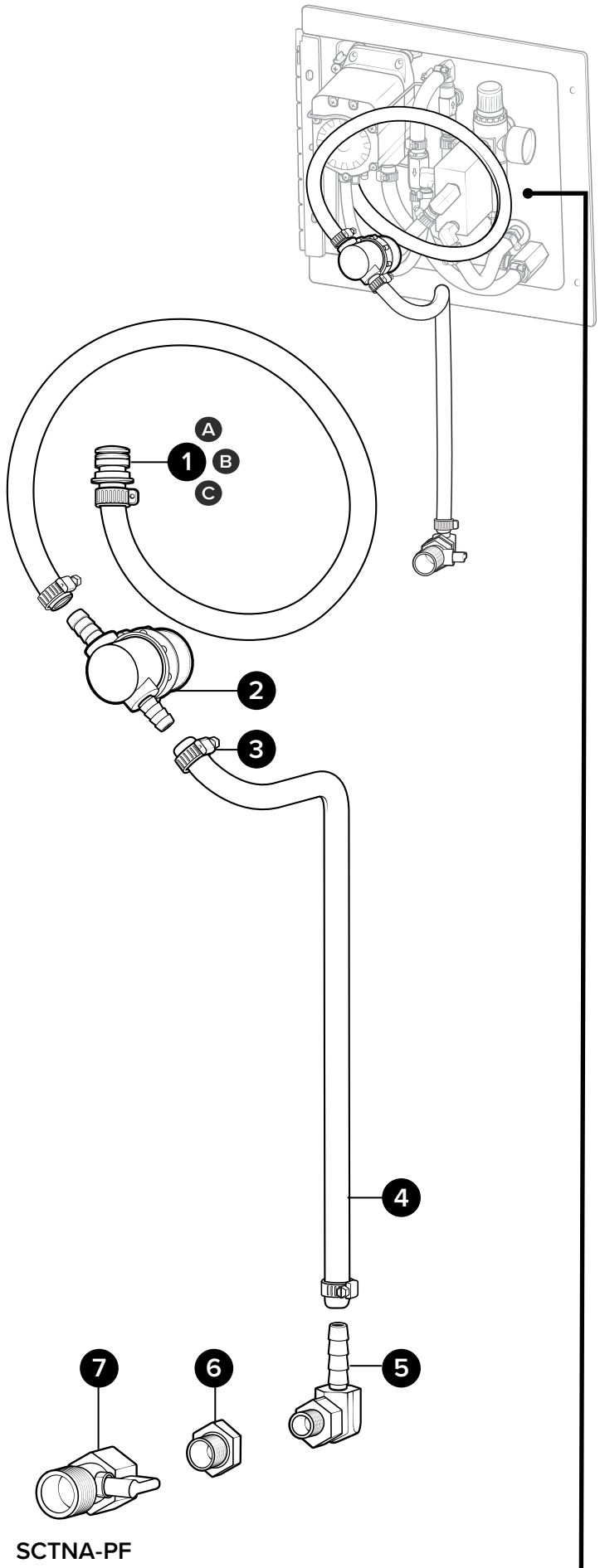

Discharge Assembly

SMWA-HA5814BL-30:

Smart wand assembly with 30 ft. of 5/8 in. and 1/4 in. bonded blue hose - includes poly smart handle, 6 in. wand, spray tip, SS ferruled 5/8 in. hose barb, 1/4 in. Oetiker clamp, and screw band clamps

Item number	Description
1 H5814BL	5/8 in. id and 1/4 in. id bonded blue hose - EPDM rubber - available per ft.
2 SMWA	Smart wand assembly for 5/8 in. and 1/4 in. bonded blue hose - poly smart handle with 6 in. wand - ST65150SS spray tip, SS hose barbs, and screw band clamps
3 SSC58	Screw band clamp - stainless steel - for 5/8 in. hose
4 SSC14	Screw band clamp - stainless steel - for 1/4 in. hose

AKSS5814:

Stainless anti-kink spring for 1/2 in. hose

Item number	Description
5 AKSS5814	Anti-kink spring - stainless - for 5/8 in. id and 1/4 in. id bonded hose

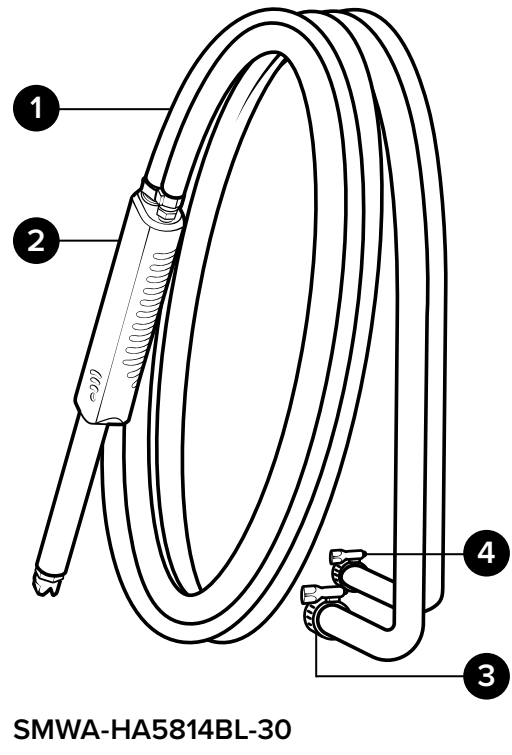
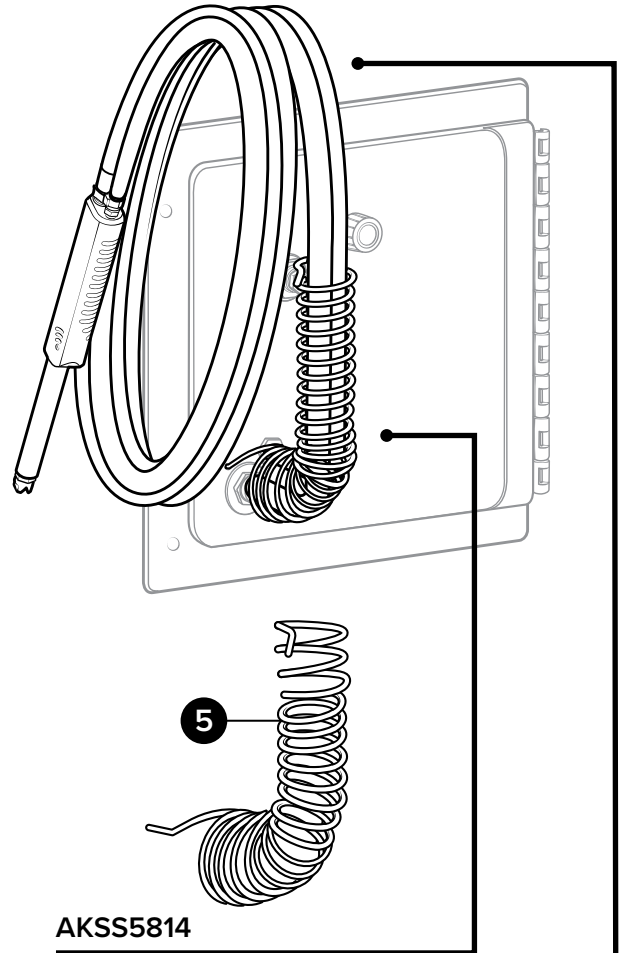

Discharge Sub-assemblies

SMWA:

Smart wand assembly for 5/8 in. and 1/4 in. bonded blue hose includes poly smart handle with 6 in. wand, ST65150SS spray tip, SS hose barbs, and screw band clamps

Item number	Description
1 SSC58	Screw band clamp - stainless steel - for 5/8 in. hose
2 SSC14	Screw band clamp - stainless steel - for 1/4 in. hose
3 HBSS1258	Stainless hose barb 1/2 MPT x 1/2 barb
4 HBSS1814	Stainless hose barb 1/8 MPT x 1/4 barb
5 SMH	Handle for bonded hose - 1/2 in. FPT and 1/8 in. FPT - UHMW
6 PW12M38F6	1/2 in. NPT and 3/8 in. FNPT wand - black UHMW - 6 in. long
7 ST65150SS	Spray tip - 65 degree - 15.0 GPM - stainless - 3/8 MPT

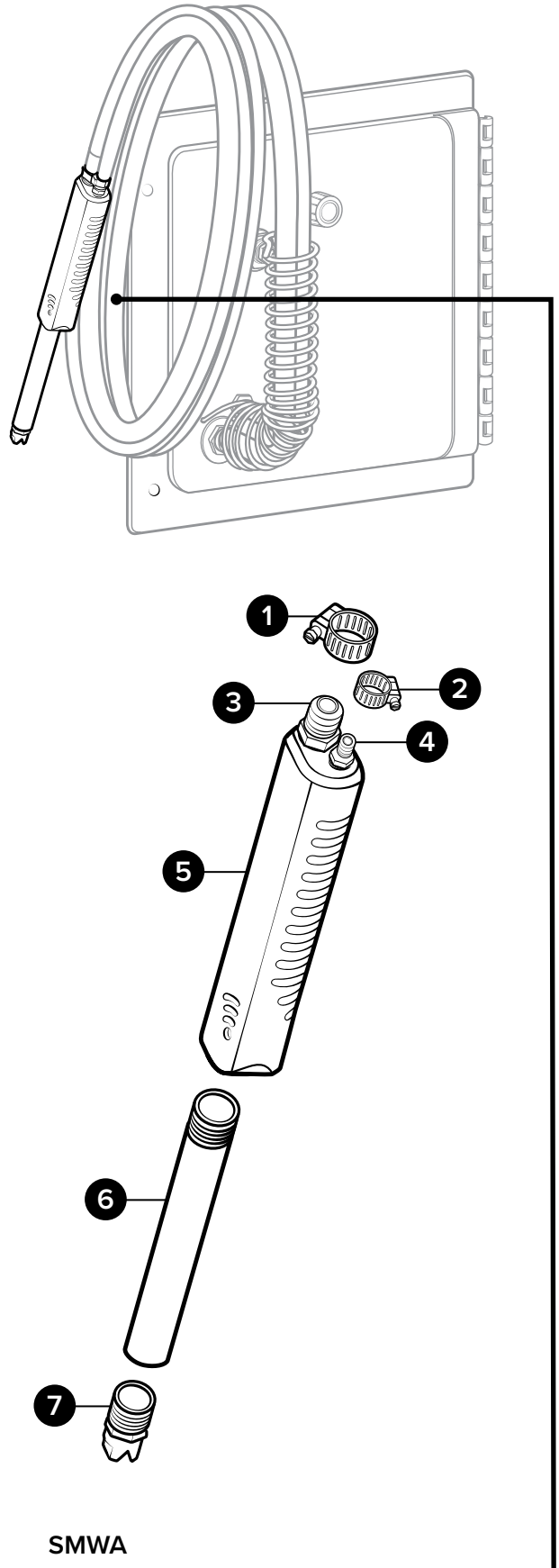

Optional Attachment

SMWA-EXT:

Smart wand assembly - handheld hose extension with 6 ft. of ½ in blue hose - includes SS coupler and 2x ferruled hose barb

Item number	Description
1	SC1212 SS coupler ½ in. x ½ in.
2	HBSS1212 Hose barb - stainless steel - ½ in. MPT x ½ in. barb
3	H12BL-F ½ in. id blue hose - hybrid TPE - available per ft.
4	EC12 Ear clamp - Oetiker - stainless steel - for ½ in. hose

