

2.5 / 5 Gallon Chemical Jug With Locking Cap

Service Manual

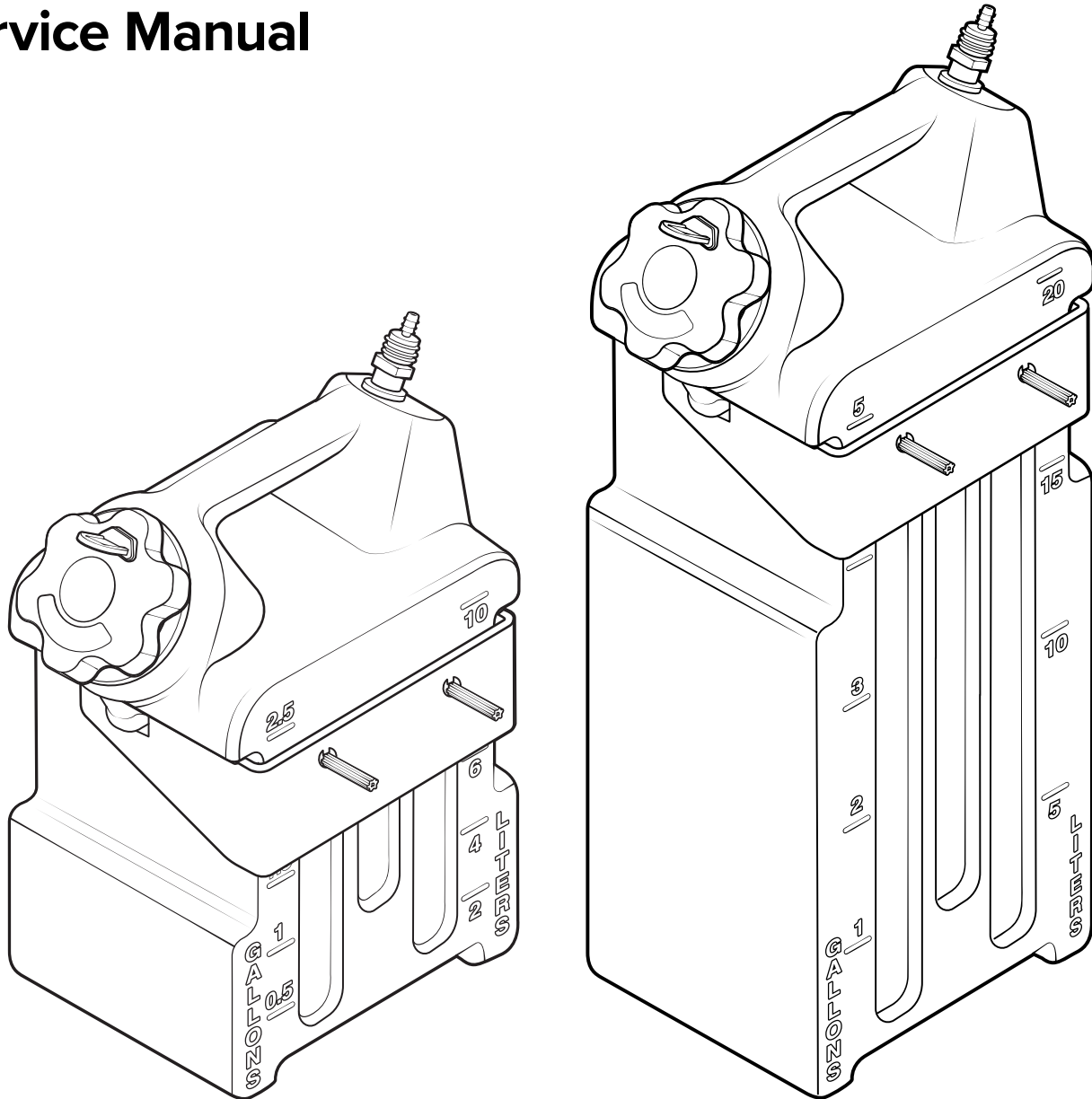

READ ALL INSTRUCTIONS BEFORE USING OR
SERVICING THIS UNIT. KEEP THIS MANUAL IN A
LOCATION THAT IS READILY AVAILABLE TO USERS
AND SERVICE TECHNICIANS.

English (Original Instructions)



Scan this code for
service manual



Safety

WARNING

PEOPLE OR OBJECTS CAN BE HURT OR DAMAGED IF THIS UNIT IS NOT USED CORRECTLY!



Failure to read all the instructions before operating the unit may result in personal injury or death from the improper use or the chemical solution. Anyone handling, operating or using the unit must read and understand the instructions in the manual. The buyer assumes all responsibility for safety and proper use in accordance with the instructions.



Using or servicing the unit without appropriate personal protective equipment (PPE) may result in serious injury such as burns, rashes, eye, throat or lung damage and death. Always wear PPE as indicated in the Safety Data Sheet (SDS) when using or servicing the unit. Protect eyes, skin, and lungs against drifting spray.



Chemical solutions may pose a health risk and death if they contact the skin or eyes, are inhaled or swallowed. Always read and follow all chemical safety precautions and handling instructions provided by the chemical manufacturer and the SDS associated with the chemical solution before using the unit.

Using the unit with fluid temperatures above 100°F (37.8°C) may result in scalding, burns, serious injury or death. DO NOT use a solution with a temperature above 100°F (37.8°C).



Operating the unit when damaged or leaking may result in exposure to chemical solutions, serious injury or death. Never use the unit if it is damaged or leaking.

Use of hydrocarbons and flammable products may result in explosions, fire and serious injury or death. Never use hydrocarbons or flammable products with the unit.



Mixing an alkaline with an acid may result in a chemical reaction. Overheating of the mixture may cause it to splatter caustic compounds or release hazardous fumes, gas and vapors. Always flush the unit with fresh water thoroughly when switching from an alkaline to an acid or an acid to an alkaline.

NOTICE

Servicing or modifying this unit with parts not listed in this manual may cause the unit to operate improperly. Do not use unauthorized parts when servicing the unit.

PROTECT THE ENVIRONMENT



Please dispose of packaging materials, old machine components, and hazardous fluids in an environmentally safe way according to local waste disposal regulations

Service Guide

WARNING

Using or servicing the unit without appropriate personal protective equipment (PPE) may result in serious injury such as burns, rashes, eye, throat or lung damage and death. Always wear PPE as indicated in the Safety Data Sheet (SDS) when using or servicing the unit. Servicing or modifying this unit with parts not listed in this manual may cause the unit to operate improperly. Do not use unauthorized parts when servicing the unit.

Maintaining Your Unit

To keep your unit operating properly, periodically perform the following maintenance procedures:

- Inspect the unit for wear and leaks.
- Inspect all hoses for leaks or excessive wear. Make sure all fittings are in good condition and properly secured.
- Check the suction line and strainer for debris. Clean as needed.

Servicing Your Unit

Most repairs on the unit can be performed with the following tools:

- Crescent wrench
- Hose cutters
- Knife

Chemical Jug

JG-2.5N-FTSW:

2.5 gallon natural chemical jug - fine thread spin weld - jug only - no locking cap or suction

Item number	Description
1	JG-2.5N-FTSW 2.5 gallon natural chemical jug fine thread spin weld - jug only

JG-5N-FTSW:

5 gallon natural chemical jug - fine thread spin weld - jug only - no locking cap or suction

Item number	Description
2	JG-5N-FTSW 5 gallon natural chemical jug - fine thread spin weld - jug only

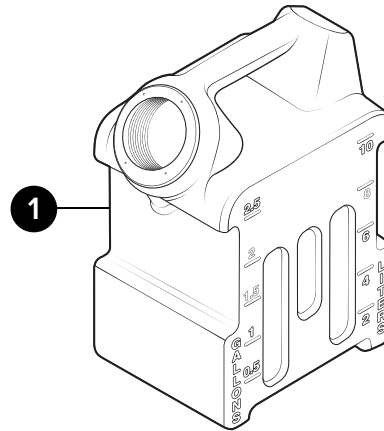
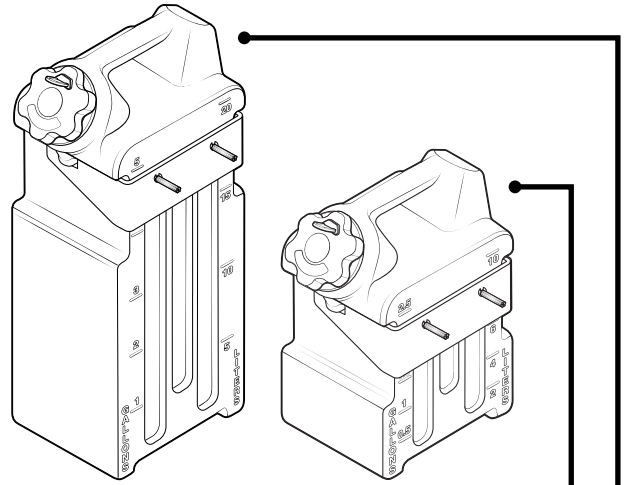

JG-2.5N-FTSW

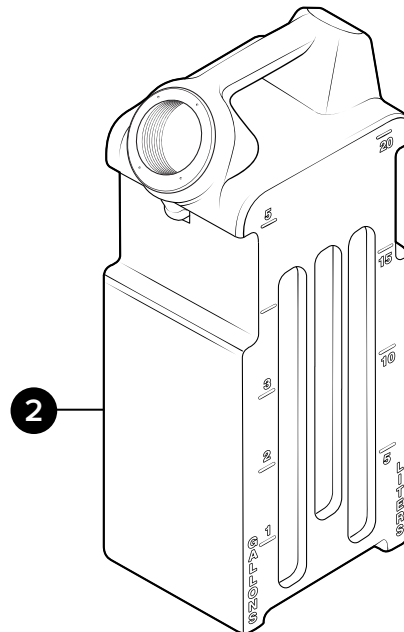

JG-5N-FTSW

Cap Assembly

LICPA-BK-FT-NVNT:

Locking cap assembly - black* - 2 in. fine thread unvented - includes Buna gasket and SS key - for units without suction

Item number	Description
1 KYSS-LICP	Key - stainless steel - for locking cap
2 LICPA-BK-FT-NVNT	Locking cap assembly - black* - 2 in. fine thread unvented - includes Buna gasket and SS key - for units without suction
3 GSKT-LICP-FT	Gasket - Buna - for locking caps with fine threads

* Additional colors available, see datasheet for options.

LICPA-BK-FT-VNT:

Locking cap assembly - black* - 2 in. fine thread vented - includes Buna gasket and SS key - for units with suction

Item number	Description
4 KYSS-LICP	Key - stainless steel - for locking cap
5 LICPA-BK-FT-VNT	Locking cap assembly - black* - 2 in. fine thread vented - includes Buna gasket and SS key - for units without suction
6 GSKT-LICP-FT	Gasket - Buna - for locking caps with fine threads

* Additional colors available, see datasheet for options.

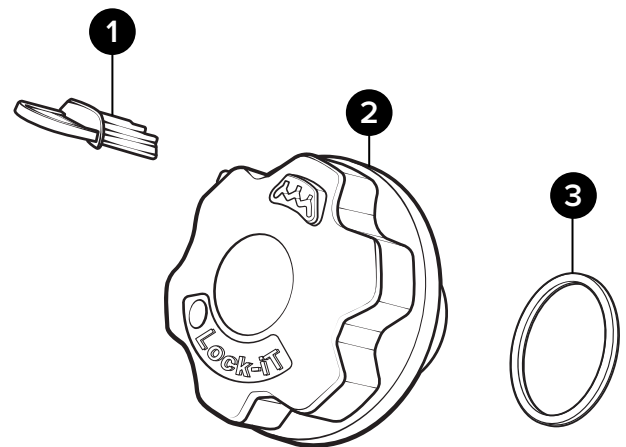
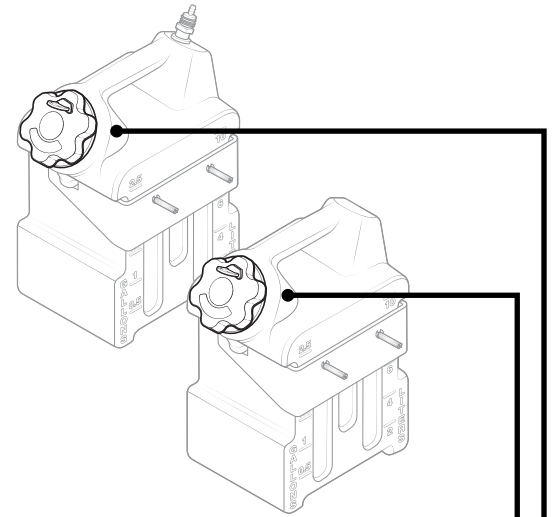

LICPA-BK-FT-NVNT

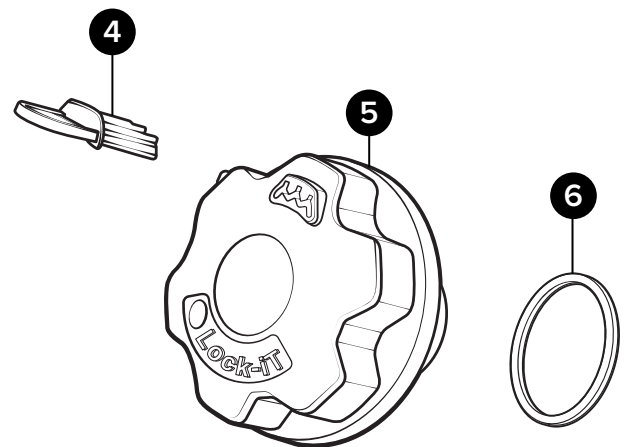

LICPA-BK-FT-VNT

Rack Assembly

WMA-JG:

Wall mount bracket assembly - for 2.5 gallon and 5 gallon jugs - includes mounting hardware

Item number	Description
1 WMBRKT-JG	Wall mount bracket - stainless steel - for jug mount
2 WMS14	Wall mount screw - #14 x 1 1/4 in. - stainless steel - hex head slotted
3 WMS14A	Wall mount screw anchor - #14 x 1 1/4 in. - plastic - 5/16 in. drill size

WMA-JG-LI:

Wall mount bracket assembly - for 2.5 gallon and 5 gallon jugs - lockable - includes mounting hardware

Item number	Description
4 ARM-JG-LI	Arm - stainless steel - for lockable jug mount bracket
5 WMBRKT-JG-LI	Wall mount bracket - stainless steel - for jug mount - lockable
6 WMS14	Wall mount screw - #14 x 1 1/4 in. - stainless steel - hex head slotted
7 WMS14A	Wall mount screw anchor - #14 x 1 1/4 in. - plastic - 5/16 in. drill size

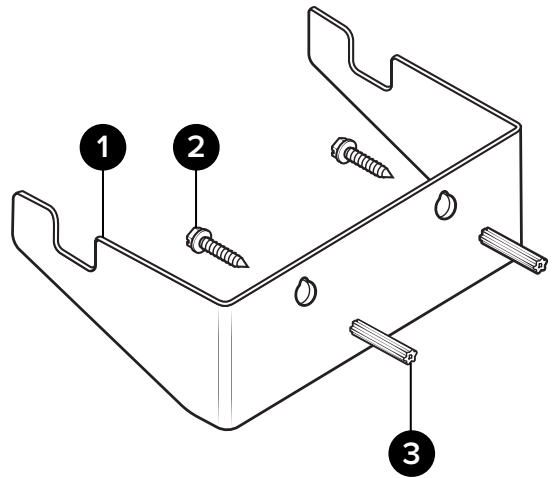
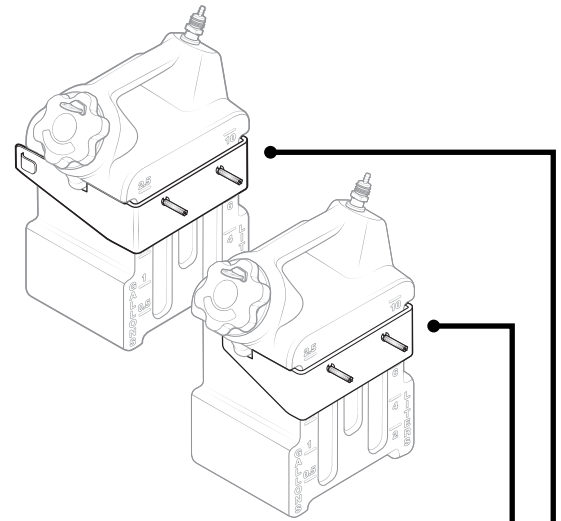

WMA-JG

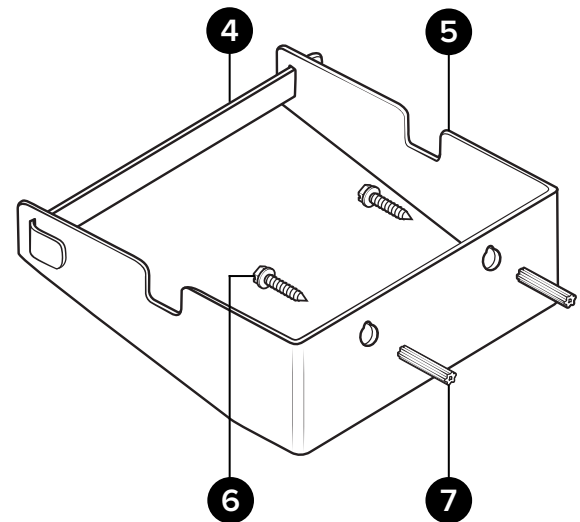

WMA-JG-LI

Suction Assembly

2.5 gallon

SCTNA-JG-2.5-NB:

Suction assembly for 2.5 gallon chemical jug - includes hose, foot strainer, and quick connect socket - no hose barb

Item number	Description
1	SCTNA-JG-2.5-NF Suction assembly - 2.5 Gal chemical jug - hose and foot strainer - no fittings
2	QCPP-SCKT-PM Quick connect socket - PP body with Hastelloy spring - barb for 3/8 in id hose - 11/16-24 panel mount threads

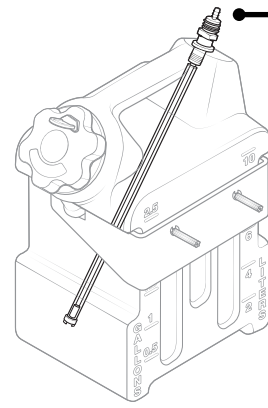

SCTNA-JG-2.5-WB:

Suction assembly for 2.5 gallon chemical jug - includes hose, foot strainer, quick connect socket, hose barb, and clamp

Item number	Description
3	SCTNA-JG-2.5-NF Suction assembly - 2.5 Gal chemical jug - hose and foot strainer - no fittings
4	QCPP-SCKT-PM Quick connect socket - PP body with Hastelloy spring - barb for 3/8 in id hose - 11/16-24 panel mount threads
5	QCPP-PLG-HB14 Quick connect plug - PP body with Hastelloy spring - barb for 1/4 in. id hose
6	SSC38 Screw band clamp for 3/8 in. hose - stainless

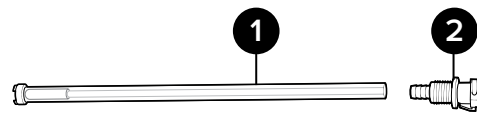

SCTNA-JG-2.5-NB



SCTNA-JG-2.5-WB

SCTNA-JG-2.5-WBEL:

Suction assembly for 2.5 gallon chemical jug - includes hose, foot strainer, quick connect socket, hose barb elbow, and clamp

Item number	Description
7	SCTNA-JG-2.5-NF Suction assembly - 2.5 Gal chemical jug - hose and foot strainer - no fittings
8	QCPP-SCKT-PM Quick connect socket - PP body with Hastelloy spring - barb for 3/8 in id hose - 11/16-24 panel mount threads
9	QCPP-PLG-HBEL14 Quick connect plug - PP body with Hastelloy spring - elbow barb for 1/4 in. id hose
10	SSC14 Screw band clamp for 1/4 in. hose - stainless

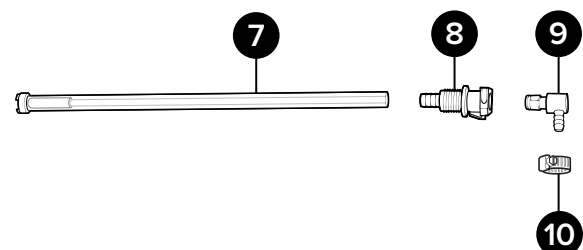

SCTNA-JG-2.5-WBEL

Suction Assembly

5 gallon

SCTNA-JG-5-NB:

Suction assembly for 5 gallon chemical jug - includes hose, foot strainer, and quick connect socket - no hose barb

Item number	Description
1 SCTNA-JG-5-NF	Suction assembly - 5 gal chemical jug - hose and foot strainer - no fittings
2 QCPP-SCKT-PM	Quick connect socket - PP body with Hastelloy spring - barb for 3/8 in id hose - 11/16-24 panel mount threads

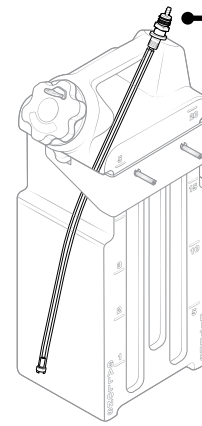

SCTNA-JG-5-WB:

Suction assembly for 5 gallon chemical jug - includes hose, foot strainer, quick connect socket, hose barb, and clamp

Item number	Description
3 SCTNA-JG-5-NF	Suction assembly - 5 gal chemical jug - hose and foot strainer - no fittings
4 QCPP-SCKT-PM	Quick connect socket - PP body with Hastelloy spring - barb for 3/8 in id hose - 11/16-24 panel mount threads
5 QCPP-PLG-HB14	Quick connect plug - PP body with Hastelloy spring - barb for 1/4 in. id hose
6 SSC38	Screw band clamp for 3/8 in. hose - stainless

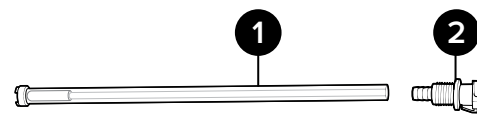

SCTNA-JG-5-NB



SCTNA-JG-5-WB

SCTNA-JG-5-WBEL:

Suction assembly for 5 gallon chemical jug - includes hose, foot strainer, quick connect socket, hose barb elbow, and clamp

Item number	Description
7 SCTNA-JG-5-NF	Suction assembly - 5 Gal chemical jug - hose and foot strainer - no fittings
8 QCPP-SCKT-PM	Quick connect socket - PP body with Hastelloy spring - barb for 3/8 in id hose - 11/16-24 panel mount threads
9 QCPP-PLG-HBEL14	Quick connect plug - PP body with Hastelloy spring - elbow barb for 1/4 in. id hose
10 SSC14	Screw band clamp for 1/4 in. hose - stainless

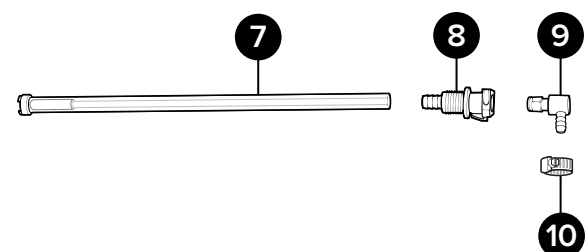

SCTNA-JG-5-WBEL